

SPECIFICATION	
VOLTAGE (VDC)	3.15
AMPS/PHASE	1.8
RESISTANCE/PHASE (Ohms)@25°C	1.75±15%
INDUCTANCE/PHASE (mH) @1KHz	3.3±20%
SPINDLE PITCH (mm) [in]	2 [0.078]
TRUST (N) (lb)	300 [67.44]
RESOLUTION (mm/STEP)	0.010
STATIC TRUST (NO CURRENT)	
MAX. SPEED (mm/sec.)	80
MAX. SPEED WITH MAX. TRUST (mm/sec.)	8
WEIGHT (Kg) [lb]	0.34 [0.75]
TEMPERATURE RISE: MAX.80°C (MOTOR STANDSTILL; FOR 2 PHASE ENERGIZED)	
AMBIENT TEMPERATURE -10°~ 50°C [14°F ~ 122°F]	
INSULATION RESISTANCE 100 MOhm (UNDER NORMAL TEMPERATURE AND HUMIDITY)	
INSULATION CLASS B 130° [266°F]	
DIELECTRIC STRENGTH 500VAC FOR 1 MIN. (BETWEEN THE MOTOR COILS AND THE MOTOR CASE)	
AMBIENT HUMIDITY MAX. 85% (NO CONDENSATION)	

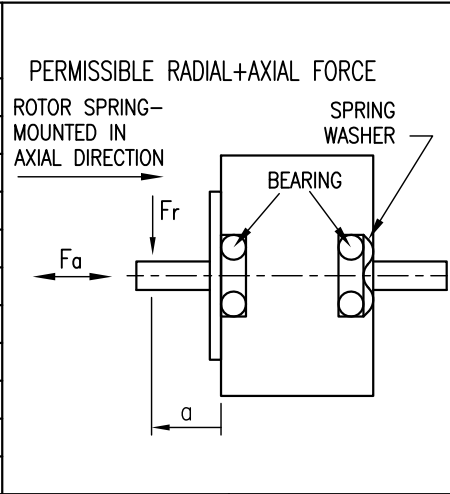

AXIAL-FORCE Fa (N)	Fa=7			
DISTANCE a (mm)	5	10	15	20
RADIAL-FORCE Fr (N)	58	36	26	20
		AXIAL	RADIAL	
SHAFT PLAY (mm)	0.08		0.02	
AT LOAD MAX: (N)	4.5		4.5	

PIN NO	TYPE OF CONNECTION (EXTERN)		MOTOR	
	BIPOLAR	LEADS	WINDING	
1	A —	BRN	A	
2	A\ —	ORG	A\<	
3	B —	RED	B	
4	B\ —	YEL	B\<	

FULL STEP 2 PHASE-Ex., WHEN FACING MOUNTING END (X)

STEP	A	B	A\<	B\<	CCW	CW
1	+	+	-	-	↓	↑
2	-	+	+	-	↑	↓
3	-	-	+	+	↓	↑
4	+	-	-	+	↑	↓

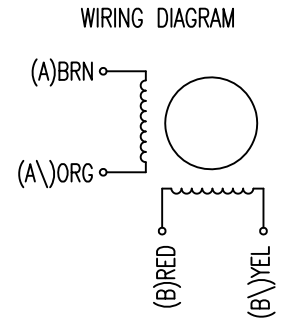

				 Nanotec [®] PLUG & DRIVE	SCALE FREE	APVD	S.H.	04.06.09	LINEAR AKTUATOR DWG.NO L4118L1804-T6x2
					X ±0.5	CHKD			
				1PL ±0.2	DRN	J.W.	04.06.09		
REV	DESCRIPTION	DATE	APVD	L4118L1804-T6x2	2PL ±0.1	SIGNATURE	DATE		
				ANGLE ±30'					