

Front view and mounting

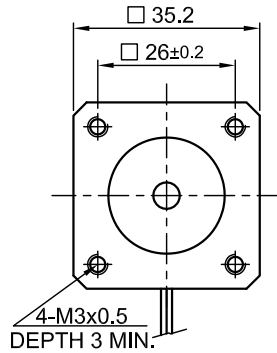

Side view

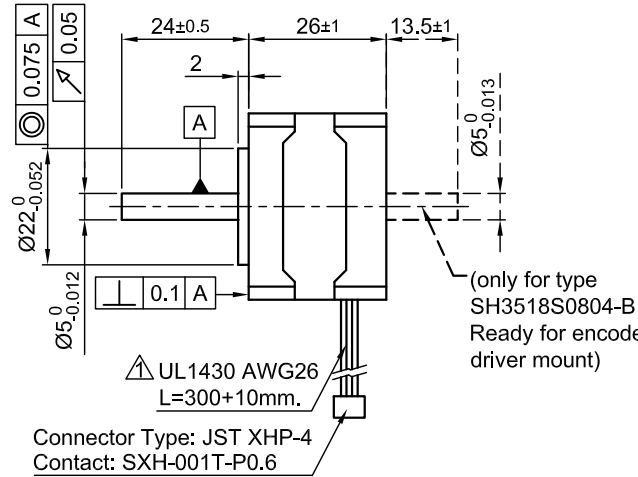

Rear view

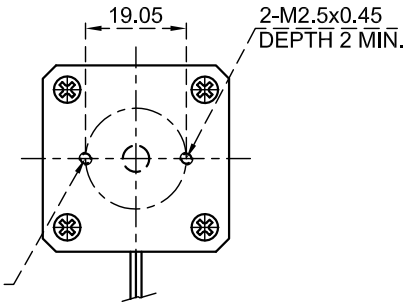

SPECIFICATION	CONNECTION	BIPOLAR
VOLTAGE (VDC)		3.2
AMPS/PHASE		0.8
RESISTANCE/PHASE (Ohms)@25°C		4.0±15%
INDUCTANCE/PHASE (mH) @1KHz		2.3±20%
HOLDING TORQUE (Nm) [lb-in]		0.051 [0.451]
DETENT TORQUE (Nm) [lb-in]		2.55x10 ⁻³ [0.023]
STEP ANGLE (°)		1.8
STEP ACCURACY (NON-ACCUM)		±5%
ROTOR INERTIA (Kg-m ²) [lb-in ²]		1.0x10 ⁻⁶ [0.0034]
WEIGHT (Kg) [lb]		0.15 [0.331]
TEMPERATURE RISE: MAX.80°C (MOTOR STANDSTILL; FOR 2 PHASE ENERGIZED)		
AMBIENT TEMPERATURE -10~ 50°C [14°F ~ 122°F]		
INSULATION RESISTANCE 100 MOhm (UNDER NORMAL TEMPERATURE AND HUMIDITY)		
INSULATION CLASS B 130° [266°F]		
DIELECTRIC STRENGTH 500VAC FOR 1 MIN. (BETWEEN THE MOTOR COILS AND THE MOTOR CASE)		
AMBIENT HUMIDITY MAX. 85% (NO CONDENSATION)		

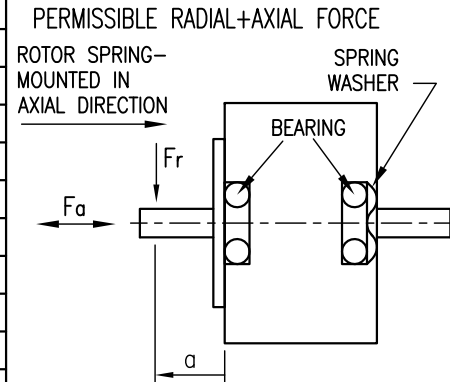

AXIAL-FORCE Fa (N)	Fa=10			
DISTANCE a (mm)	5	10	15	20
RADIAL-FORCE Fr (N)	58	36	26	20
		AXIAL	RADIAL	
SHAFT PLAY (mm)		0.08	0.02	
AT LOAD MAX: (N)		4.5	4.5	

TYPE OF CONNECTION (EXTERN)	MOTOR		
	CONNECTOR PIN NO.	LEADS	WINDING
A —	1	WHT	A
A\ —	2	RED	A\
B —	3	BLU	B
B\ —	4	YEL	B\

FULL STEP 2 PHASE-Ex., WHEN FACING MOUNTING END (X)

STEP	A	B	A\	B\	
1	+	+	-	-	CCW
2	-	+	+	-	
3	-	-	+	+	
4	+	-	-	+	CW

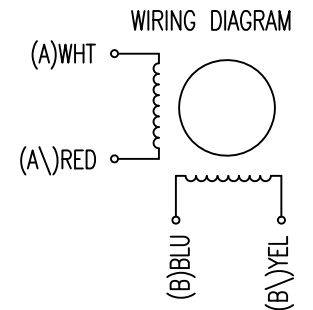

REV	DESCRIPTION	DATE	APVD	Nanotec® PLUG & DRIVE		SCALE FREE	APVD	S.Ha.	08.12.08	STEPPING MOTOR	
1	UL NO.	05.03.09	J.W.	ST3518S0804		X ±0.5	CHKD			DWG.NO ST3518S0804	
REV	DESCRIPTION	DATE	APVD			1PL ±0.2	DRN	J.W.	08.12.08		
						2PL ±0.1	SIGNATURE	DATE			
						ANGLE ±30'					