

(only for type ST4118S1404-B Ready for encoder + driver mount)

SPECIFICATION	CONNECTION	BIPOLAR
VOLTAGE (VDC)		2.8
AMPS/PHASE		1.4
RESISTANCE/PHASE (Ohms)@25°C		2.0±15%
INDUCTANCE/PHASE (mH) @1KHz		3.6±20%
HOLDING TORQUE (Nm) [lb-in]		0.2 [1.77]
DETENT TORQUE (Nm) [lb-in]		6.0x10 ⁻³ [5.31x10 ⁻²]
STEP ANGLE (°)		1.8
STEP ACCURACY (NON-ACCUM)		±5%
ROTOR INERTIA (Kg-m ²) [lb-in ²]		3.8x10 ⁻⁶ [1.3x10 ⁻²]
WEIGHT (Kg) [lb]		0.2 [0.441]
TEMPERATURE RISE: MAX.80°C (MOTOR STANDSTILL; FOR 2 PHASE ENERGIZED)		
AMBIENT TEMPERATURE -10°~ 50°C [14°F ~ 122°F]		
INSULATION RESISTANCE 100 MOhm (UNDER NORMAL TEMPERATURE AND HUMIDITY)		
INSULATION CLASS B 130° [266°F]		
DIELECTRIC STRENGTH 500VAC FOR 1 MIN. (BETWEEN THE MOTOR COILS AND THE MOTOR CASE)		
AMBIENT HUMIDITY MAX. 85% (NO CONDENSATION)		

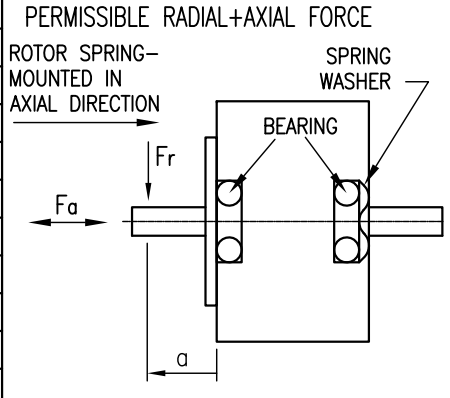

AXIAL-FORCE Fa (N)	Fa=7			
DISTANCE a (mm)	5	10	15	20
RADIAL-FORCE Fr (N)	58	36	26	20
	AXIAL	RADIAL		
SHAFT PLAY (mm)	0.08	0.02		
AT LOAD MAX: (N)	4.5	4.5		

PIN NO	TYPE OF CONNECTION (EXTERN)		MOTOR	
	BIPOLAR	LEADS	WINDING	
1	A —	BRN	A	[Circuit diagram showing A and A\ windings]
2	A\ —	ORG	A\	
3	B —	RED	B	[Circuit diagram showing B and B\ windings]
4	B\ —	YEL	B\	

FULL STEP 2 PHASE-Ex., WHEN FACING MOUNTING END (X)

STEP	A	B	A\	B\	
1	+	+	-	-	CCW
2	-	+	+	-	
3	-	-	+	+	CW
4	+	-	-	+	

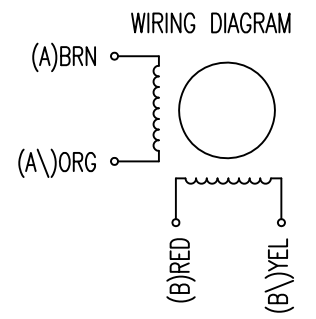

1	UL NO.	17.07.08	J.W.
REV	DESCRIPTION	DATE	APVD

Nanotec
PLUG & DRIVE

ST4118S1404

SCALE FREE	APVD	S.Ha.	26.02.07
X ±0.5	CHKD		
1PL ±0.2	DRN	J.W.	16.10.06
2PL ±0.1	SIGNATURE	DATE	
ANGLE ±30'			

STEPPING MOTOR

DWG.NO ST4118S1404