

ST5918S3008-L HYBRID STEPPING MOTOR

specifications:

PHASE	STEP ANGLE DEG/STEP		RATED VOLTAGE	CURRENT /PHASE	RESISTANCE /PHASE	INDUCTANCE /PHASE	HOLDING TORQUE	ROTOR INERTIA	WEIGHT
			V	A	ohms	mH	N.cm	gcm ²	Kg
4	1.8	Unipolar	2.16	3.0	0.72	1.1	65	275	0.65

Wiring Diagram:

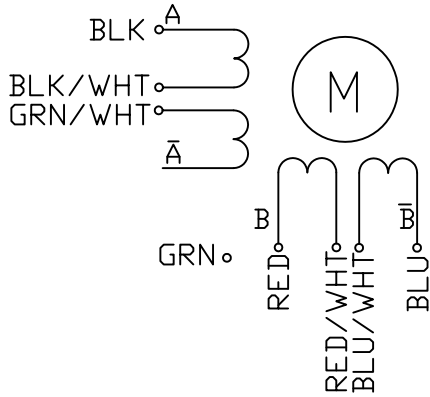

PIN#	LEADERS
1	BLK
2	GRN/WHT
3	BLK/WHT
4	GRN
5	RED
6	BLU/WHT
7	RED/WHT
8	BLU

SEE FROM REAR SHAFT END

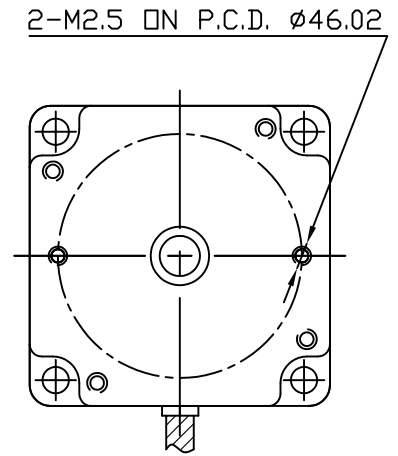

Dimension:

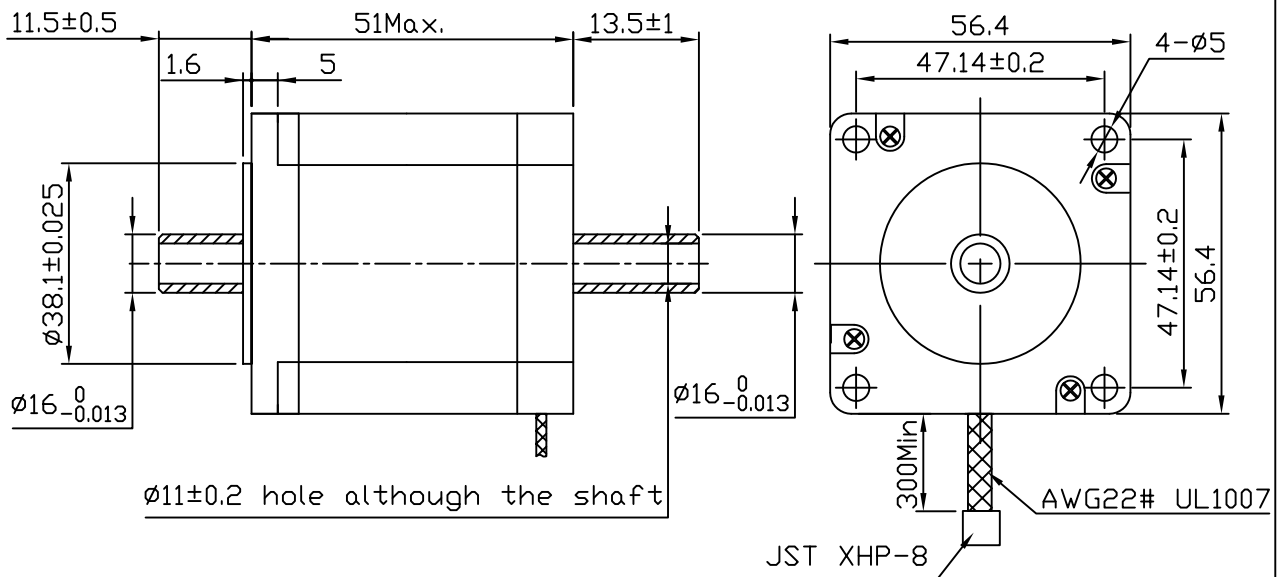

REV.	QTY.	NO.	SIG.	surfacetreat			
DESIGN				NANOTEC.	CLS.MAK	WEIGHT	SCALE
CHECK				ST5918S3008-L			
PROC.							
DT.	12.09.2006			MATERIAL:	PAGE:	OF	PAGES
STD.							
APPROVE					ST5918S3008-L		