

Front view and mounting

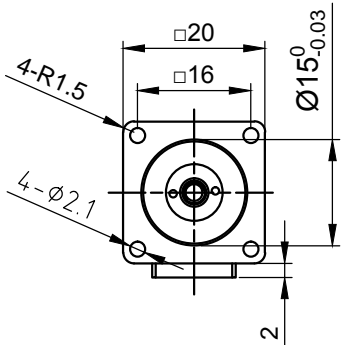

Side view

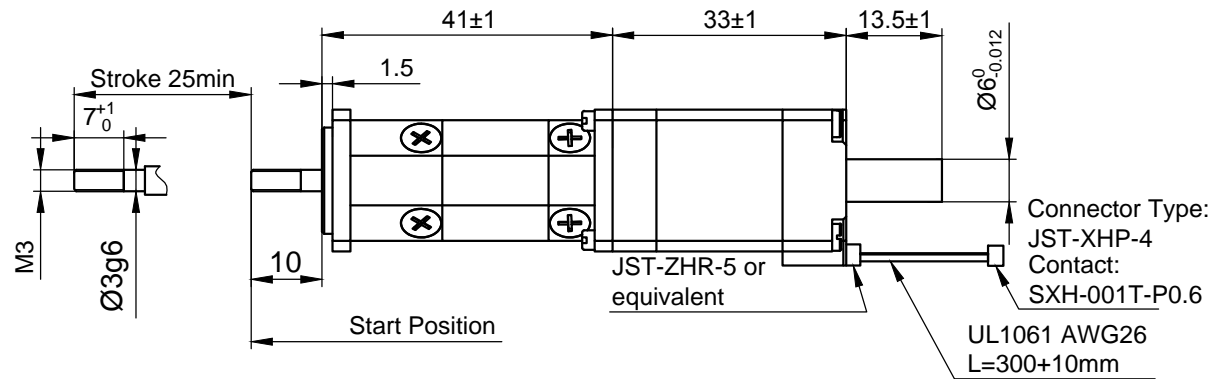

Rear view

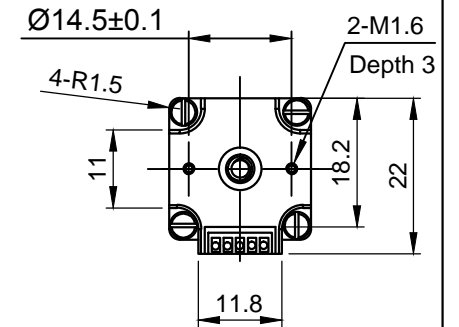

SPECIFICATION	
AMPS/PHASE	0.6
RESISTANCE/PHASE (Ohms)@25°C	6.5±15%
INDUCTANCE/PHASE (mH) @1KHz	2±20%
SPINDLE PITCH (mm) [in]	1 [0.039]
THRUST (N) [lbf]	30[6.74] \triangle ₃
PEAK THRUST (N) [lb]	40[8.99] \triangle ₄
PEAK CURRENT (A)	0.8 \triangle ₄
RESOLUTION (mm/FULLSTEP)	0.005
STATIC THRUST (N) [lbf] (NO CURRENT)	>30[6.74] \triangle ₃
MAX. SPEED (mm/sec.) AT 48V	40
MAX. SPEED WITH MAX. THRUST (mm/sec.) AT 48V	1 \triangle ₃
WEIGHT (Kg) [lb]	0.09[0.198]
TEMPERATURE RISE: MAX.80°C (MOTOR STANDSTILL; FOR 2 PHASE ENERGIZED)	
AMBIENT TEMPERATURE -10°C ~ 50°C [14°F ~ 122°F]	
INSULATION RESISTANCE 100 MOhm (UNDER NORMAL TEMPERATURE AND HUMIDITY)	
INSULATION CLASS B 130° [266°F]	
DIELECTRIC STRENGTH 500VAC FOR 1 MIN. (BETWEEN THE MOTOR COILS AND THE MOTOR CASE)	
AMBIENT HUMIDITY MAX. 85% (NO CONDENSATION)	

Please regard the application note at www.nanotec.com for further informations.

Shaft play is adjustable at the motor.

TYPE OF CONNECTION (EXTERN)	MOTOR		
	BIPOLAR	LEADS	WINDING
PIN NO			
1	A —	BK	A
2	A\ —	GN	A\ B
3	B —	RD	B
4	B\ —	BU	B\ A

WIRING DIAGRAM

FULL STEP 2 PHASE-Ex., WHEN FACING MOUNTING END (X)

STEP	A	B	A\ B	B\ A	CCW	CW
1	+	+	-	-	↓	↑
2	-	+	+	-	↓	↑
3	-	-	+	+	↓	↑
4	+	-	-	+	↓	↑

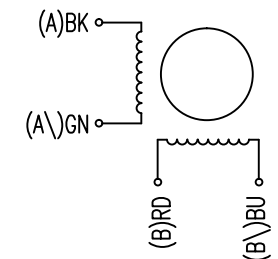

3	CHANGE DATA	12.03.14	B.L.
2	NEW ARTICLE NO.	06.06.12	J.W.
4	CHANGE DATA	30.07.14	B.L.
REV	DESCRIPTION	DATE	APVD



L2018S0604-T3,5x1-25 \triangle

SCALE	FREE	APVD	HZQ	16.01.12
X	±0.5	CHKD	GYQ	16.01.12
1PL	±0.2	DRN	L B	16.01.12
2PL	±0.1	SIGNATURE	DATE	
ANGLE	±30°			

LINEAR MOTOR

DWG.NO

L2018S0604-T3,5x1-25 \triangle