

Front view and mounting

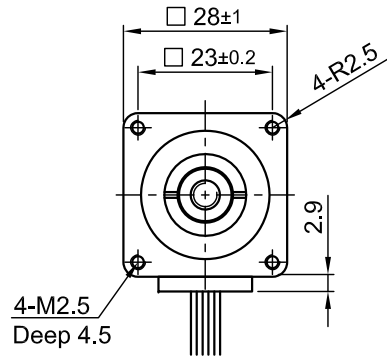

Side view

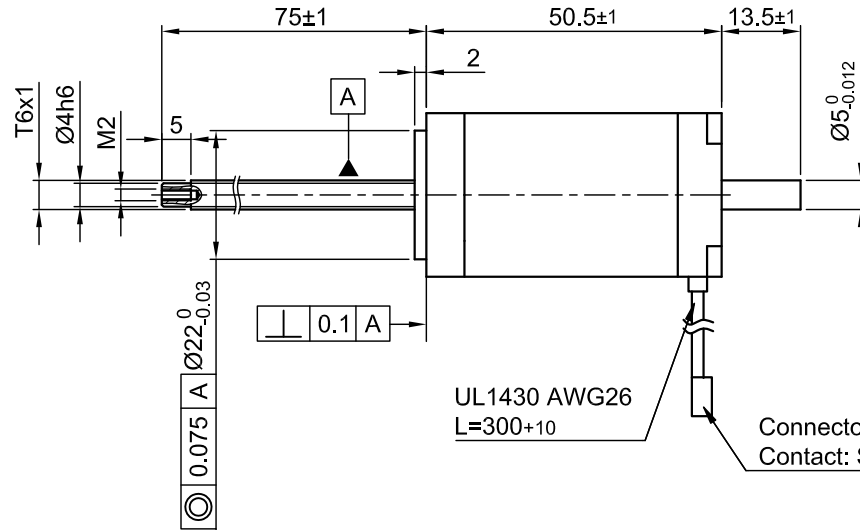

Rear view

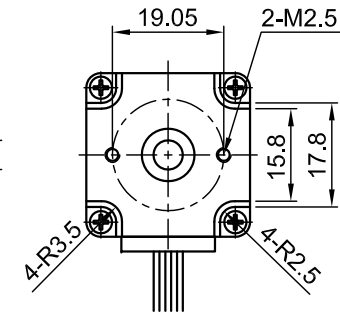

UL1430 AWG26
L=300+10

Connector Type: JST XHP-4
Contact: SXH-001T-P0.6

SPECIFICATION	CONNECTION	BIPOLAR
AMPS/PHASE		0.67
RESISTANCE/PHASE (Ohms)@25°C		9.2±15%
INDUCTANCE/PHASE (mH) @1KHz		7.2±20%
THRUST (N) [lbf]		120 [27]
RESOLUTION (mm/STEP)		0.005
STATIC THRUST (N) [lbf] (NO CURRENT)		170 [38.25]
MAX. SPEED (mm/sec.) AT 48V		30
MAX. SPEED WITH MAX. THRUST (mm/sec.) AT 48V		10
STEP ANGLE (°)+ACCURACY		1.8±5%
WEIGHT (Kg) [lb]		0.28 [0.617]
TEMPERATURE RISE: MAX.80°C (MOTOR STANDSTILL; FOR 2 PHASE ENERGIZED)		
AMBIENT TEMPERATURE -10°~ 50°C [14°F ~ 122°F]		
INSULATION RESISTANCE 100 MOhm (UNDER NORMAL TEMPERATURE AND HUMIDITY)		
INSULATION CLASS B 130° [266°F]		
DIELECTRIC STRENGTH 500VAC FOR 1 MIN. (BETWEEN THE MOTOR COILS AND THE MOTOR CASE)		
AMBIENT HUMIDITY MAX. 85% (NO CONDENSATION)		

Please regard the application note at www.nanotec.com for further informations.

Shaft play is adjustable at the motor.

TYPE OF CONNECTION (EXTERN)	MOTOR		
	BIPOLAR	LEADS	WINDING
PIN NO			
1	A —	BLK	A
2	A\ —	GRN	A\
3	B —	RED	B
4	B\ —	BLU	B\

WIRING DIAGRAM

FULL STEP 2 PHASE-Ex., WHEN FACING MOUNTING END (X)

STEP	A	B	A\	B\	CCW
1	+	+	-	-	↓ ↑
2	-	+	+	-	
3	-	-	+	+	
4	+	-	-	+	

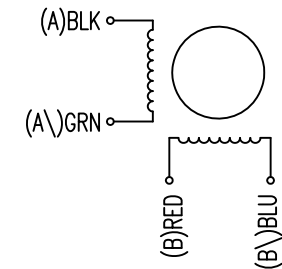

REV	DESCRIPTION	DATE	APVD	LS2818L0604-T6x1-75	SCALE FREE	APVD	CHKD	DRN	SIGNATURE	DATE	DWG.NO
					X ±0.5		LB			22.09.11	LINEAR AKTUATOR
					1PL ±0.2		GYQ			22.09.11	
					2PL ±0.1						LS2818L0604-T6x1-75
					ANGLE ±30'						