

PSBN

The high-performance precision planetary gearbox with helical teeth for a particularly quiet drive

Our **PSBN** is the ideal combination of precision planetary gearbox and efficient bearing technology. It has been developed specifically for delivering the maximum performance at high speeds. Its helical teeth provide homogeneous synchronism and quiet running noise.

1 Helical teeth for enhanced quality

This is progress: The innovative helical teeth of the **PSBN** safeguard the optimal, homogeneous synchronism. Vibrations are minimized for greater workpiece surface and printed quality.

2 The highest speed for the best performance

Thanks to its low-friction bearing design and optimized lubrication, the **PSBN** operates with particular reliability and low heat generation – even in complex production cycles.

3 Particularly quiet drive

Our Neugart-developed helical teeth save you money. The **PSBN** does not need expensive sound absorption measures on your machine. The value of the whole system increases as a result.

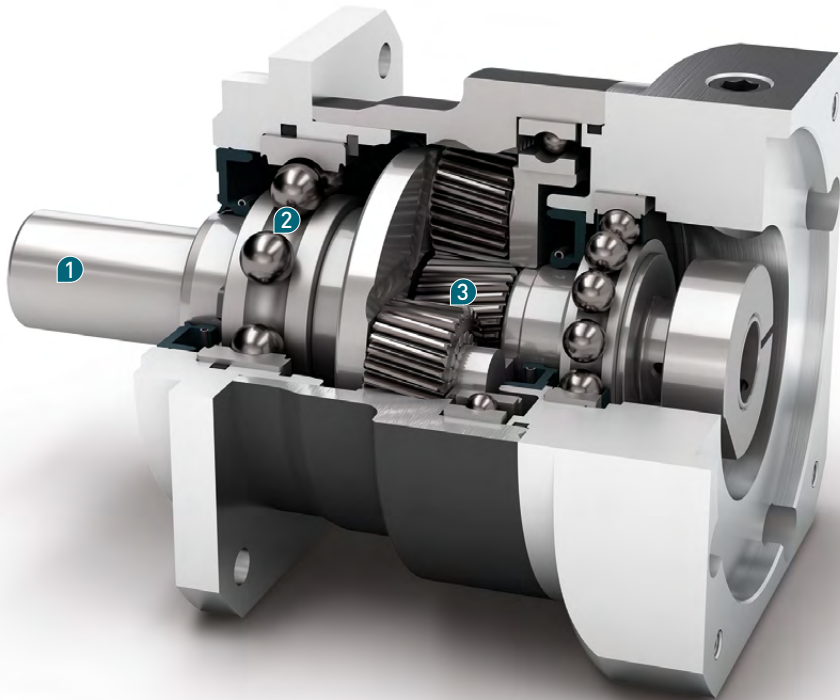

PSBN

- + Minimized backlash for maximized precision (< 1 arcmin)
- + For any mounting position
- + Individual adaptation of the input flange to the motor
- + Lifetime lubrication for maintenance-free operation
- + Equidirectional rotation
- + Wide range of output shaft designs
- + Clamping systems with optimized mass moment of inertia

Code	Gearbox characteristics			PSBN070	PSBN090	PSBN115	z ⁽¹⁾
	Service life	t _L	h	20,000			
	Service life at T _{2N} × 0.88			30,000			
	Efficiency at full load ⁽²⁾	η	%	98			1
				96			2
	Min. operating temperature	T _{min}	°C	-25 (-13)			
	Max. operating temperature	T _{max}	(°F)	90 (194)			
	Protection class				IP 65		
S	Standard lubrication				Oil		
F	Food grade lubrication				Oil		
L	Low temperature lubrication ⁽³⁾				Oil		
	Installation position				Any		
S	Standard backlash	j _t	arcmin	< 3			1
				< 5			2
R	Reduced backlash				< 2	< 1	< 1
	Torsional stiffness ⁽²⁾	c _g	Nm/arcmin (lb _r .in/ arcmin)	3.7 - 5.0 (33 - 44)	7.8 - 10.5 (69 - 93)	21.5 - 29.0 (190 - 257)	1
				3.8 - 5.0 (34 - 44)	7.7 - 10.1 (68 - 89)	21.0 - 28.0 (186 - 248)	2
	Gearbox weight	m _G	kg (lb _m)	1.4 (3.1)	2.7 (6.0)	5.6 (12.3)	1
				2.2 (4.9)	3.7 (8.2)	7.1 (15.7)	2
S	Standard surface				Housing: Steel – nitrocarburized and post-oxidized (black)		
	Running noise ⁽⁴⁾	Q _g	dB(A)	57	58	63	
	Max. bending moment based on the gearbox input flange ⁽⁵⁾	M _b	Nm (lb _r .in)	18 (159)	38 (336)	80 (708)	1
				18 (159)	18 (159)	38 (336)	2
	Motor flange precision				DIN 42955-R		

Output shaft loads				PSBN070	PSBN090	PSBN115	z ⁽¹⁾
Radial force for 20,000 h ⁽⁶⁾⁽⁷⁾	F _{r 20.000 h}	N (lb _r)		1000 (225)	1900 (428)	2300 (518)	
Axial force for 20,000 h ⁽⁶⁾⁽⁷⁾	F _{a 20.000 h}			1500 (338)	3000 (675)	4400 (990)	
Radial force for 30,000 h ⁽⁶⁾⁽⁷⁾	F _{r 30.000 h}			850 (191)	1700 (383)	2000 (450)	
Axial force for 30,000 h ⁽⁶⁾⁽⁷⁾	F _{a 30.000 h}			1300 (293)	2500 (563)	3700 (833)	
Static radial force ⁽⁷⁾⁽⁸⁾	F _{r Stat}			1600 (360)	3100 (698)	4500 (1013)	
Static axial force ⁽⁷⁾⁽⁸⁾	F _{a Stat}			1500 (338)	2800 (630)	4500 (1013)	
Tilting moment for 20,000 h ⁽⁶⁾⁽⁸⁾	M _{K 20.000 h}	Nm (lb _r .in)		68 (602)	154 (1363)	226 (2000)	
Tilting moment for 30,000 h ⁽⁶⁾⁽⁸⁾	M _{K 30.000 h}			58 (513)	138 (1221)	197 (1743)	

Moment of inertia				PSBN070	PSBN090	PSBN115	z ⁽¹⁾
Mass moment of inertia ⁽²⁾	J	kgcm ² (lb _r .in.s ² 10 ⁻⁴)		0.126 - 0.250 (1.112 - 2.216)	0.324 - 0.760 (2.870 - 6.727)	0.862 - 2.520 (7.628 - 22.306)	1
				0.123 - 0.175 (1.091 - 1.551)	0.124 - 0.200 (1.096 - 1.768)	0.321 - 0.600 (2.838 - 5.306)	2

(1) Number of stages
(2) The ratio-dependent values can be retrieved in Tec Data Finder – www.neugart.com
(3) T_{min} = -40°C (-40°F). Optimal operating temperature max. 50°C (122°F)
(4) Sound pressure level from 1 m, measured on input running at n₁=3000 rpm no load; i=5
(5) Max. motor weight* in kg = 0.2 × M_b / motor length in m
* with symmetrically distributed motor weight
* with horizontal and stationary mounting
(6) These values are based on an output shaft speed of n₂=100 rpm
(7) Based on center of output shaft
(8) Other (sometimes higher) values following changes to T_{2N}, F_r, F_a, cycle, and service life of bearing. Application specific configuration with NCP – www.neugart.com

Output torques			PSBN070	PSBN090	PSBN115	i ⁽¹⁾	z ⁽²⁾				
Nominal output torque ⁽³⁾⁽⁴⁾	T _{2N}	Nm (lb _r .in)	29 (257)	54 (478)	135 (1195)	3	1				
			39 (345)	80 (708)	180 (1593)	4					
			40 (354)	80 (708)	175 (1549)	5					
			37 (327)	78 (690)	175 (1549)	7					
			39 (345)	75 (664)	155 (1372)	8					
			28 (248)	59 (522)	140 (1239)	10					
			29 (257)	54 (478)	135 (1195)	12	2				
			29 (257)	54 (478)	135 (1195)	15					
			39 (345)	80 (708)	180 (1593)	16					
			39 (345)	80 (708)	180 (1593)	20					
			40 (354)	80 (708)	175 (1549)	25					
			40 (354)	80 (708)	175 (1549)	35					
			39 (345)	80 (708)	180 (1593)	40					
			40 (354)	80 (708)	175 (1549)	50					
			37 (327)	78 (690)	175 (1549)	70					
			28 (248)	59 (522)	140 (1239)	100					
			Max. output torque ⁽⁴⁾⁽⁵⁾	T _{2max}	Nm (lb _r .in)	46 (407)		86 (761)	216 (1912)	3	1
						62 (549)		128 (1133)	288 (2549)	4	
64 (566)	128 (1133)	280 (2478)				5					
59 (522)	125 (1106)	280 (2478)				7					
62 (549)	120 (1062)	248 (2195)				8					
45 (398)	94 (832)	224 (1982)				10					
46 (407)	86 (761)	216 (1912)				12	2				
46 (407)	86 (761)	216 (1912)				15					
62 (549)	128 (1133)	288 (2549)				16					
62 (549)	128 (1133)	288 (2549)				20					
64 (566)	128 (1133)	280 (2478)				25					
64 (566)	128 (1133)	280 (2478)				35					
62 (549)	128 (1133)	288 (2549)				40					
64 (566)	128 (1133)	280 (2478)				50					
59 (522)	125 (1106)	280 (2478)				70					
45 (398)	94 (832)	224 (1982)				100					

(1) Ratios (i=n₁/n₂)
 (2) Number of stages
 (3) Application specific configuration with NCP – www.neugart.com
 (4) Values for feather key (code "A"): for repeated load
 (5) 30,000 rotations of the output shaft permitted; see page 128

Output torques			PSBN070	PSBN090	PSBN115	i ⁽¹⁾	z ⁽²⁾
Emergency stop torque ⁽³⁾	T _{2Stop}	Nm (lb _f .in)	90 (797)	210 (1859)	490 (4337)	3	1
			120 (1062)	280 (2478)	650 (5753)	4	
			130 (1151)	280 (2478)	650 (5753)	5	
			80 (708)	175 (1549)	340 (3009)	7	
			90 (797)	200 (1770)	380 (3363)	8	
			90 (797)	200 (1770)	480 (4248)	10	
			135 (1195)	220 (1947)	500 (4425)	12	2
			135 (1195)	220 (1947)	500 (4425)	15	
			150 (1328)	300 (2655)	650 (5753)	16	
			150 (1328)	300 (2655)	650 (5753)	20	
			150 (1328)	300 (2655)	650 (5753)	25	
			150 (1328)	300 (2655)	650 (5753)	35	
			150 (1328)	300 (2655)	650 (5753)	40	
			150 (1328)	300 (2655)	650 (5753)	50	
			80 (708)	175 (1549)	340 (3009)	70	
			80 (708)	200 (1770)	480 (4248)	100	

Input speeds			PSBN070	PSBN090	PSBN115	i ⁽¹⁾	z ⁽²⁾
Average thermal input speed at T _{2N} and S1 ⁽⁴⁾⁽⁵⁾	n _{1N}	rpm	3800 ⁽⁶⁾	3400 ⁽⁶⁾	2900 ⁽⁶⁾	3	1
			4400 ⁽⁶⁾	3700 ⁽⁶⁾	3000 ⁽⁶⁾	4	
			4600 ⁽⁶⁾	3900 ⁽⁶⁾	3500 ⁽⁶⁾	5	
			5000	4500	4000 ⁽⁶⁾	7	
			5000	4500	4000	8	
			5000	4500	4000	10	
			5000	5000	4500	12	2
			5000	5000	4500	15	
			5000	5000	4500	16	
			5000	5000	4500	20	
			5000	5000	4500	25	
			5000	5000	4500	35	
			5000	5000	4500	40	
			5000	5000	4500	50	
			5000	5000	4500	70	
			5000	5000	4500	100	
Max. mechanical input speed ⁽⁴⁾	n _{1Limit}	rpm	14000	10000	8500		1
			14000	14000	10000		2

⁽¹⁾ Ratios (i=n₁/n₂)

⁽²⁾ Number of stages

⁽³⁾ Permitted 1000 times

⁽⁴⁾ Application-specific speed configurations with NCP – www.neugart.com

⁽⁵⁾ See page 128 for the definition

⁽⁶⁾ Average thermal input speed at 50% T_{2N} and S1

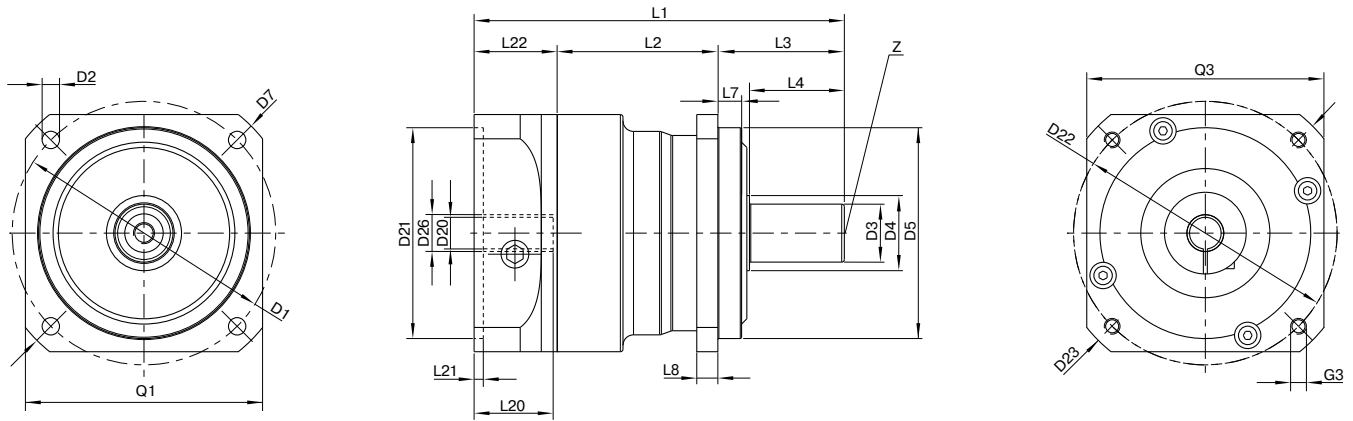

Drawing corresponds to a PSBN090 / 1-stage / smooth output shaft / 14 mm clamping system / motor adaptation – 2-part – round universal flange / B5 flange type motor
 All other variants can be retrieved in the Tec Data Finder at www.neugart.com

Geometry ⁽¹⁾			PSBN070	PSBN090	PSBN115	z ⁽²⁾	Code
Pitch circle diameter output	D1		70 (2.756)	100 (3.937)	130 (5.118)		
Mounting bore output	D2	4x	5.5 (0.217)	6.6 (0.260)	9.0 (0.354)		
Shaft diameter output	D3	j6	16 (0.630)	22 (0.866)	32 (1.260)		
Shaft collar output	D4		23.5 (0.925)	28.5 (1.122)	38.5 (1.516)		
Centering diameter output	D5	g6	50 (1.969)	80 (3.150)	110 (4.331)		
Diagonal dimension output	D7		80 (3.150)	115 (4.528)	148 (5.827)		
Flange cross section output	Q1	■	60 (2.362)	90 (3.543)	115 (4.528)		
Min. total length	L1		116.5 (4.587)	140.5 (5.531)	182.5 (7.185)	1	
			145 (5.709)	162.5 (6.398)	204.5 (8.051)	2	
Housing length	L2		54 (2.126)	61 (2.402)	74 (2.913)	1	
			82.5 (3.248)	89 (3.504)	107.5 (4.232)	2	
Shaft length output	L3		37 (1.457)	48 (1.890)	65 (2.559)		
Centering depth output	L7		6 (0.236)	9 (0.354)	4 (0.157)		
Flange thickness output	L8		6 (0.236)	8 (0.315)	10 (0.394)		
Clamping system diameter input	D26		More information on page 117				
Motor shaft diameter j6/k6	D20		The dimensions vary with the motor/gearbox flange. The input flange geometries can be retrieved for each specific motor in Tec Data Finder at www.neugart.com				
Max. permis. motor shaft length	L20						
Min. permis. motor shaft length							
Centering diameter input	D21						
Centering depth input	L21						
Pitch circle diameter input	D22						
Motor flange length	L22						
Diagonal dimension input	D23						
Mounting thread x depth	G3	4x					
Flange cross section input	Q3	■					
Output shaft with feather key (DIN 6885-1)			A 5x5x25	A 6x6x28	A 10x8x50		A
Feather key width (DIN 6885-1)	B1		5 (0.197)	6 (0.236)	10 (0.394)		
Shaft height including feather key (DIN 6885-1)	H1		18 (0.709)	24.5 (0.984)	35 (1.378)		
Shaft length from shoulder	L4		28 (1.102)	36 (1.417)	58 (2.283)		
Feather key length	L5		25 (0.984)	28 (1.102)	50 (1.969)		
Distance from shaft end	L6		2 (0.079)	4 (0.157)	4 (0.157)		
Center hole (DIN 332, type DR)	Z		M5x12.5	M8x19	M12x28		
Smooth output shaft							B
Shaft length from shoulder	L4		28 (1.102)	36 (1.417)	58 (2.283)		
Center hole (DIN 332, type DR)	Z		M5x12.5	M8x19	M12x28		

⁽¹⁾ Dimensions in mm (in)
⁽²⁾ Number of stages