

Front view and mounting

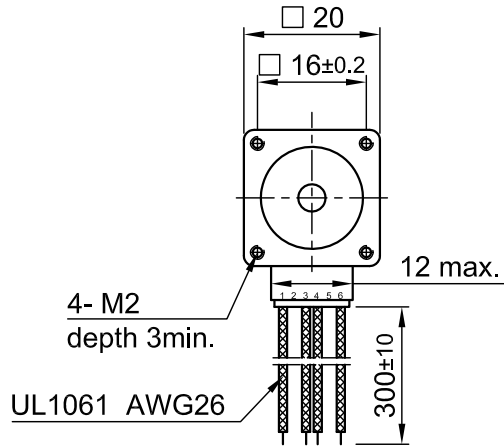

Side view

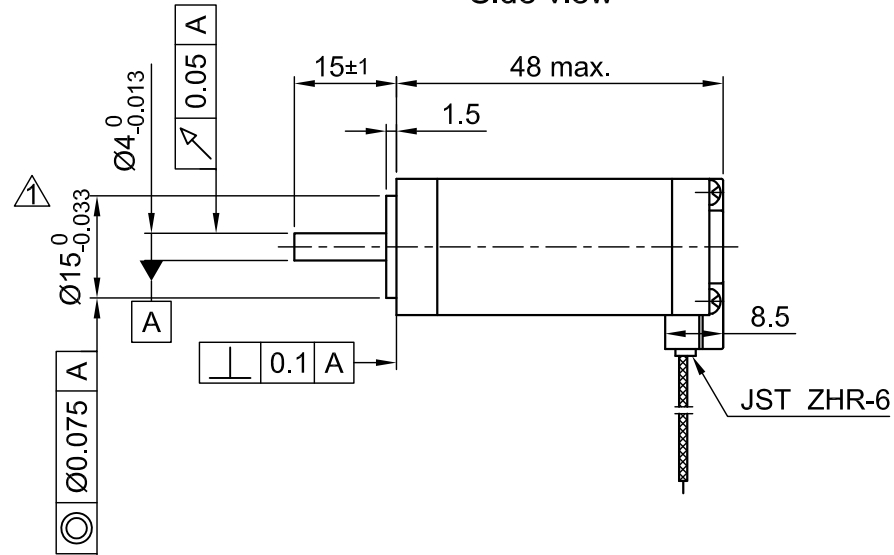

Rear view

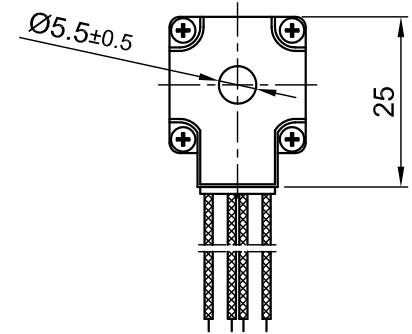

SPECIFICATION	CONNECTION	BIPOLAR
VOLTAGE (VDC)		5.12
AMPS/PHASE		0.8
RESISTANCE/PHASE (Ohms)@25°C		6.4±15%
INDUCTANCE/PHASE (mH) @1KHz		2.2±20%
HOLDING TORQUE (Nm) [lb-in]		0.036 [0.319]
DETENT TORQUE (Nm) [lb-in]		1.8x10 ⁻³ [1.6x10 ⁻²]
STEP ANGLE (°)+ ACCURACY		1.8±5%
ROTOR INERTIA (Kg-m ²) [lb-in ²]		4.3x10 ⁻⁷ [14.6x10 ⁻⁴]
WEIGHT (Kg) [lb]		0.09 [0.198]

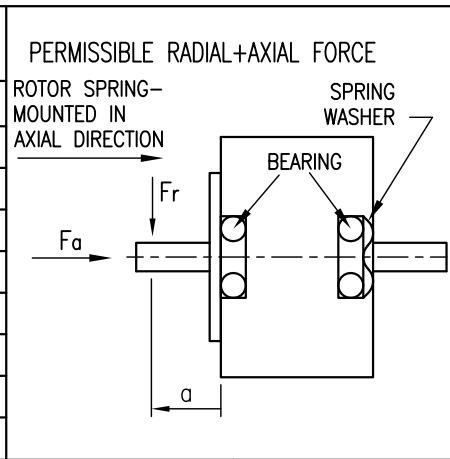

TYPE OF CONNECTION (EXTERN)	MOTOR			
	BIPOLAR	CONNECTOR PIN NO.	LEADS	WINDING
A —	1	BLK	A	
A\ —	2	GRN	A\	
B —	3	RED	B	
B\ —	4	BLU	B\	

FULL STEP 2 PHASE-Ex., WHEN FACING MOUNTING END (X)

STEP	A	B	A\	B\	CCW
1	+	+	-	-	↓
2	-	+	+	-	↑
3	-	-	+	+	↓
4	+	-	-	+	↑

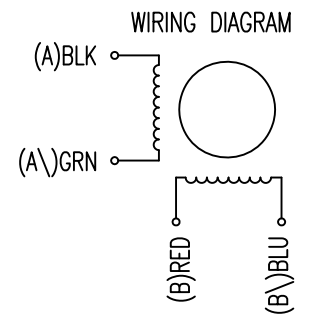

TEMPERATURE RISE: MAX.80°C (MOTOR STANDSTILL; FOR 2 PHASE ENERGIZED)	AXIAL-FORCE Fa (N)	Fa=4			
AMBIENT TEMPERATURE -10~ 50°C [14°F ~ 122°F]	DISTANCE a (mm)	5	10	15	20
INSULATION RESISTANCE 100 MOhm (UNDER NORMAL TEMPERATURE AND HUMIDITY)	RADIAL-FORCE Fr (N)	30	18	14	8
INSULATION CLASS B 130° [266°F]			AXIAL	RADIAL	
DIELECTRIC STRENGTH 500VAC FOR 1 MIN. (BETWEEN THE MOTOR COILS AND THE MOTOR CASE)	SHAFT PLAY (mm)		0.075	0.025	
AMBIENT HUMIDITY MAX. 85% (NO CONDENSATION)	AT LOAD MAX: (N)		10	5.0	

				 Nanotec [®] PLUG & DRIVE			APVD	G.S.	21.04.15	STEPPING MOTOR DWG.NO
1	change tolerance Ø15	23.02.16	A.S.	Surface specification DIN ISO 1302	General tolerances DIN ISO 2768- cH	Work piece edge DIN ISO 13715	CHKD			
REV	DESCRIPTION	DATE	DRN				DRN	A.S.	21.04.15	SC2018L0804-A